

SBT-BGA DIRECT MOUNT, SOLDERLESS SOCKET FOR BURN-IN AND TEST APPLICATIONS

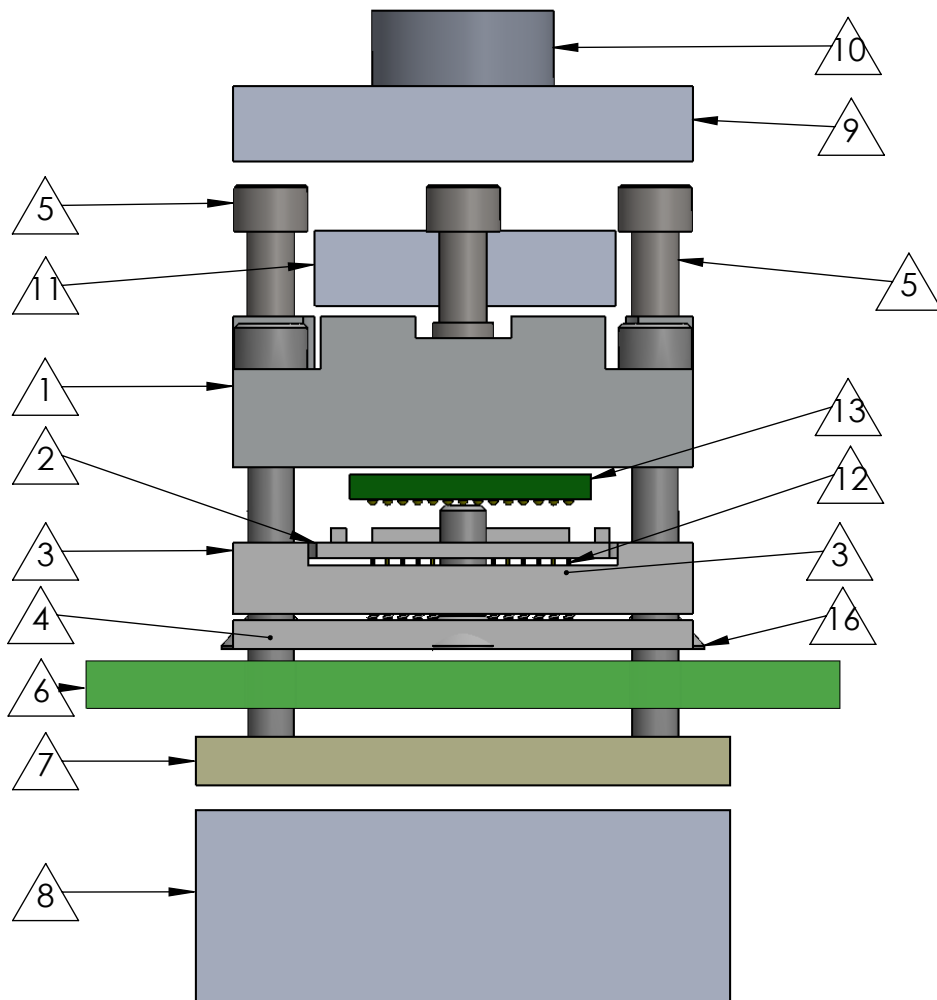

Features

- Wide temperature range (-55C to +180C)
- High current capability (up to 8A)
- Excellent signal integrity at high frequencies
- Low and stable contact resistance for reliable production yield
- Highly compliant to accommodate wide co-planarity variations
- Automated probe manufacturing enables low cost and short lead time

ITEM NO.	PART NUMBER	Description	Default/QTY.
1	M2423	Socket Base: Black Anodized Aluminium	1
2	P8369A	Floating Guide: Ceramic Filled Peek	1
3	P8370A	Middle Guide: Ceramic Filled Peek	1
4	P8371A	Bottom Guide: Ceramic Filled Peek	1
5	R2613	Socket Shoulder screw: SS- #0-80 threads	4
6	Target PCB	Customers Target PCB	1
7	P5196A	Insulation Plate: FR4	1
8	M1489	Backing Plate: Black Anodizes Aluminium	1
9	M1144	Compression Screw: Clear Anodized Aluminium	1
10	M1146	Socket Lid: Black Anodized Aluminium	1
11	M1145	Compression Plate :Black Anodized Aluminium	1
12	P-P149A	SBT-BGA 0.5mm pin	1
13	BGA196A	Customer's BGA device	1
14	R1693	Alignment Pins	2
15	R1486	Socket Base screw: Socket head cap, alloy steel with black oxide finish, 0-80 fine thread , 12.7mm long.	4
16	R1391	Pin Guide screw: Flat head, alloy steel, 0-80 fine thread , 6.3mm long.	4

Description: SBT-BGA 8x8mm, 0.5mm pitch, 14x14 array

Primary dimension units are millimeters, Secondary dimension units are [inches].

Tolerances: diameters $\pm 0.03\text{mm}$ [$\pm 0.001"$], PCB perimeters $\pm 0.13\text{mm}$ [$\pm 0.005"$], PCB thicknesses $\pm 0.18\text{mm}$ [$\pm 0.007"$], pitches (from true position) $\pm 0.08\text{mm}$ [$\pm 0.003"$], all other tolerances $\pm 0.13\text{mm}$ [$\pm 0.005"$] unless stated otherwise. Materials and specifications are subject to change without notice.

SBT-BGA-7003 Drawing

Ironwood Electronics, Inc.
Tele: (800) 404-0204
www.ironwoodelectronics.com

WEIGHT: 12.43
MATERIAL:
FINISH:

STATUS: Released

DRAWN BY: Vinayak R

File: SBT-BGA-7003

SHEET 1 OF 4

SCALE: 2:1

DATE: 5/21/2009

REV. A

*Note: BGA pattern is not symmetrical with respect to the mounting holes.

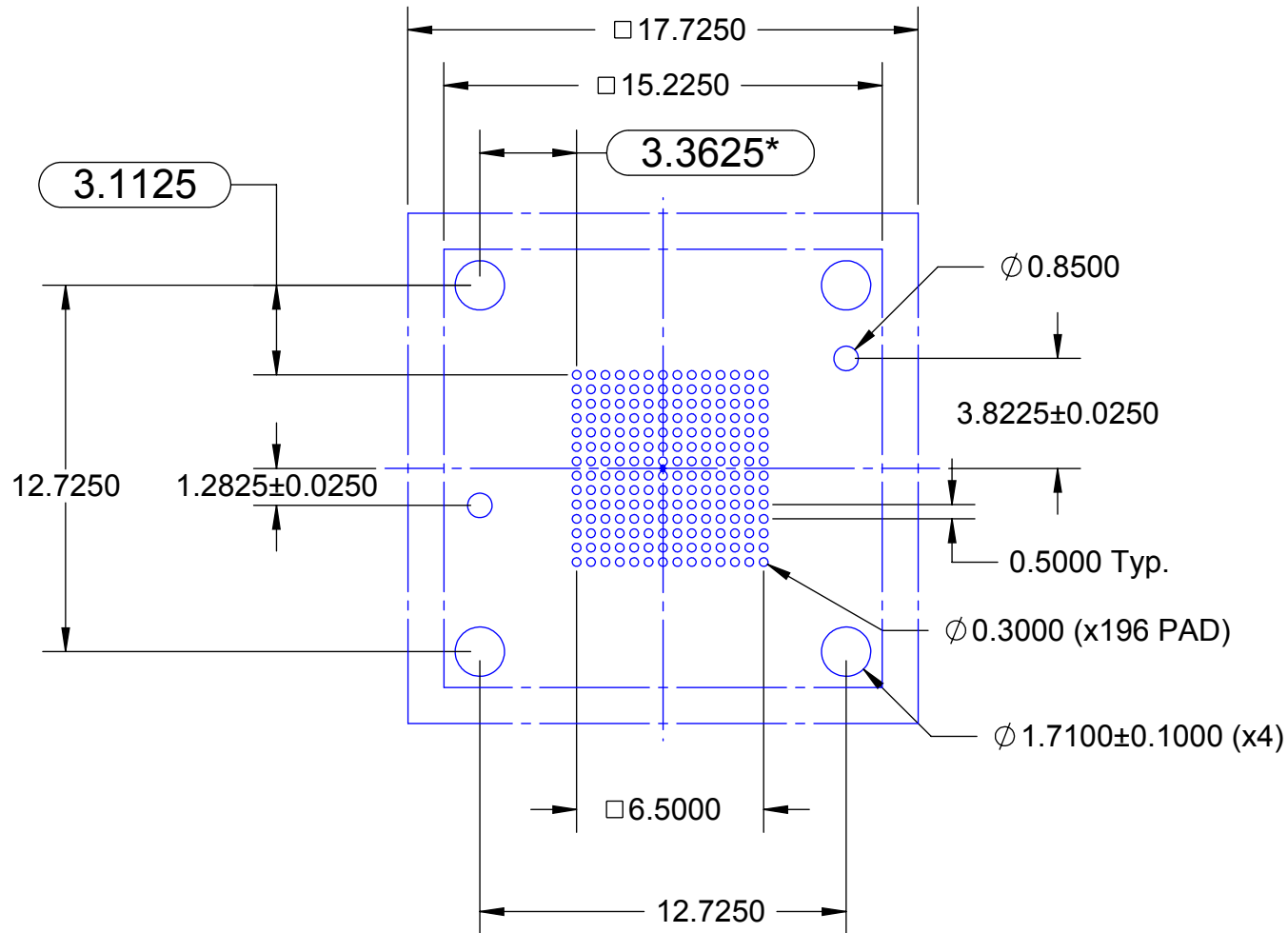

Description: SBT-BGA-7003 Recommended Layout 8x8mm, 0.5mm pitch, 14x14 array

Target PCB Recommendations
 Total thickness: 1.6mm min.
 Plating: Gold or Solder finish
 PCB Pad height: Same or higher than solder mask

Primary dimension units are millimeters, Secondary dimension units are [inches].
 Tolerances: diameters ±0.03mm [±0.001"], PCB perimeters ±0.13mm [±0.005"], PCB thicknesses ±0.18mm [±0.007"], pitches (from true position) ±0.08mm [±0.003"], all other tolerances ±0.13mm [±0.005"] unless stated otherwise. Materials and specifications are subject to change without notice.

SBT-BGA-7003 Drawing

STATUS: Released

SHEET 2 OF 4

REV. A

Ironwood Electronics, Inc.
 Tele: (800) 404-0204
 www.ironwoodelectronics.com

WEIGHT:
 MATERIAL:
 FINISH:

DRAWN BY: Vinayak R

SCALE: 4:1

File: SBT-BGA-7003

DATE: 5/21/2009

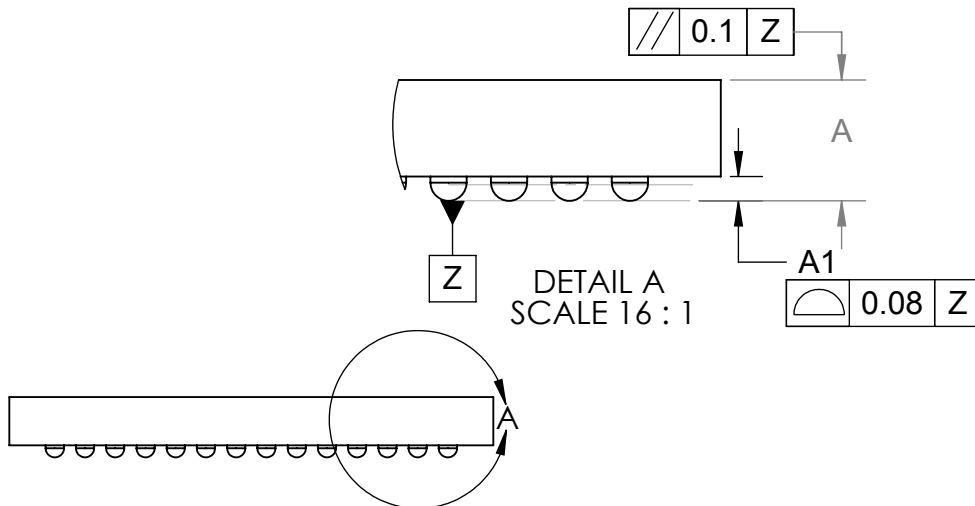
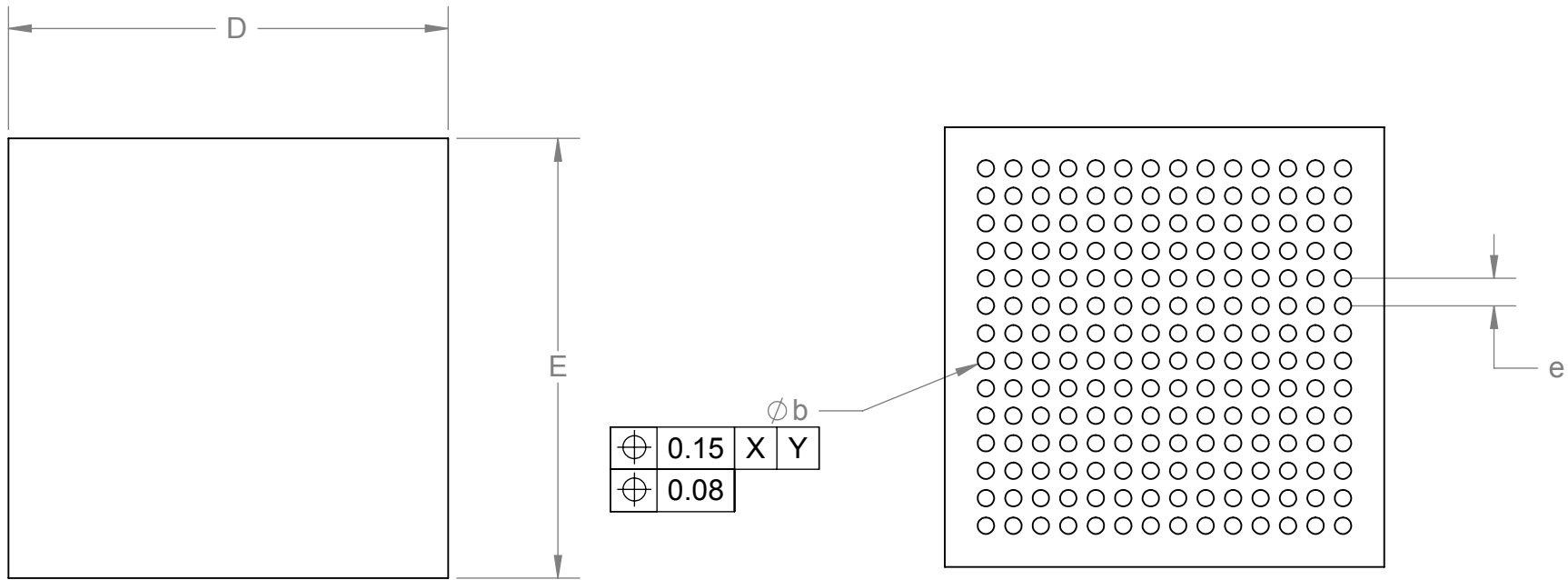

1. Dimensions are in millimeters.
2. Interpret dimensions and tolerances per ASME Y14.5M-1994.
3. Dimension b is measured at the maximum solder ball diameter, parallel to datum plane Z.
4. Datum Z (seating plane) is defined by the spherical crowns of the solder balls.
5. Parallelism measurement shall exclude any effect of mark on top surface of package.

DIM	Minimum	Maximum
A		2.5
A1	0.2	0.4
b	0.25	0.4
D	8.0 BSC	
E	8.0 BSC	
e	0.5 BSC	

Description: BGA with 196 pin with 0.5mm Pitch

Primary dimension units are millimeters, Secondary dimension units are [inches].
 Tolerances: diameters $\pm 0.03\text{mm}$ [± 0.001 "], PCB perimeters $\pm 0.13\text{mm}$ [± 0.005 "], PCB thicknesses $\pm 0.18\text{mm}$ [± 0.007 "], pitches (from true position) $\pm 0.08\text{mm}$ [± 0.003 "], all other tolerances $\pm 0.13\text{mm}$ [± 0.005 "] unless stated otherwise. Materials and specifications are subject to change without notice.

14x14 Array

SBT-BGA-7003 Drawing

Ironwood Electronics, Inc.
 Tele: (800) 404-0204
 www.ironwoodelectronics.com

WEIGHT:
 MATERIAL:
 FINISH:

STATUS:

DRAWN BY: Vinayak R

File: SBT-BGA-7003

SHEET 3 OF 4

SCALE: 8:1

DATE: 5/21/2009

REV. A

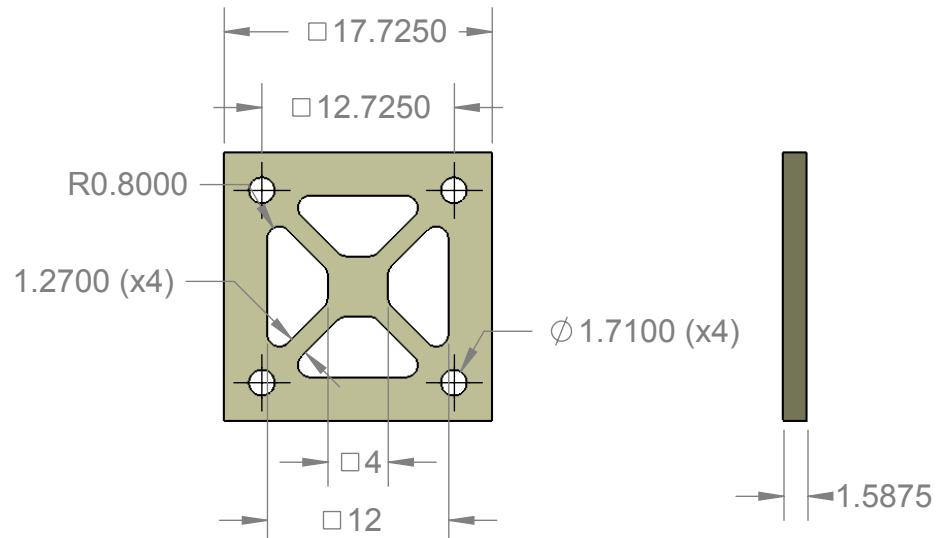
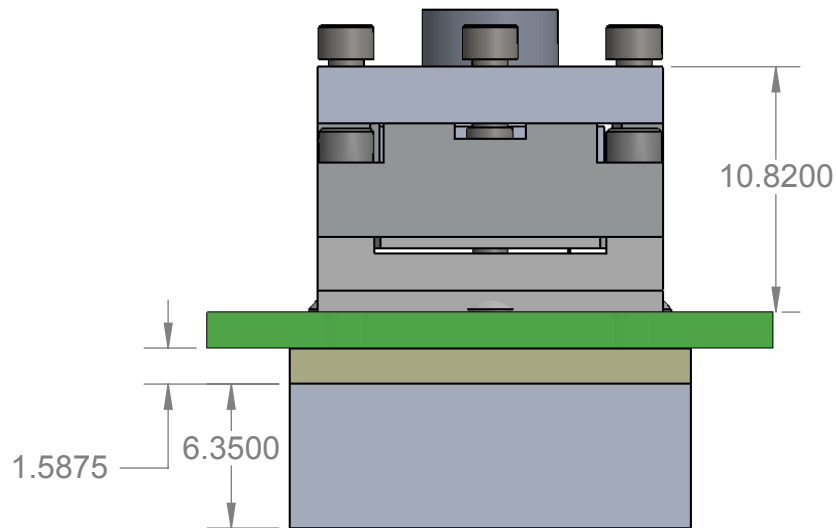
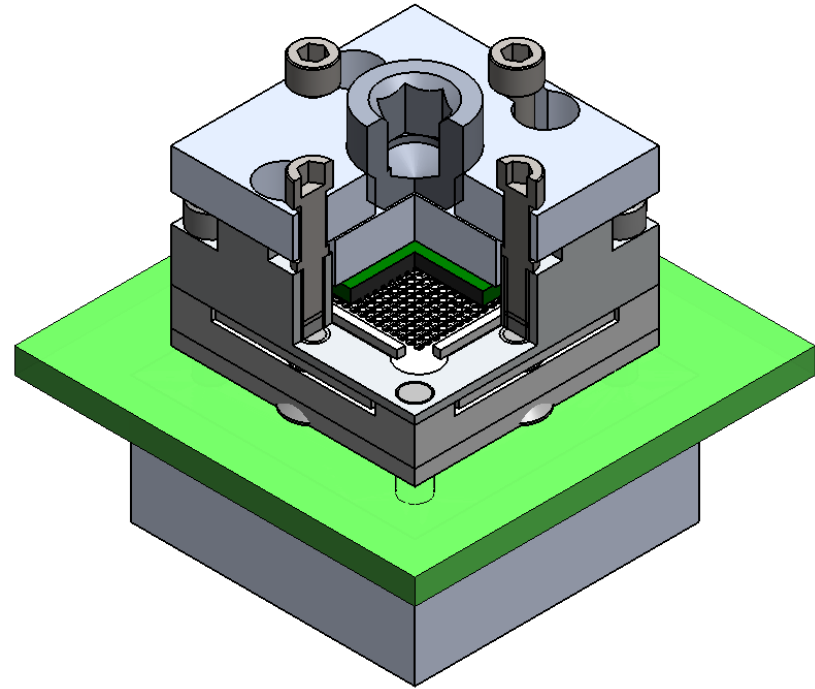
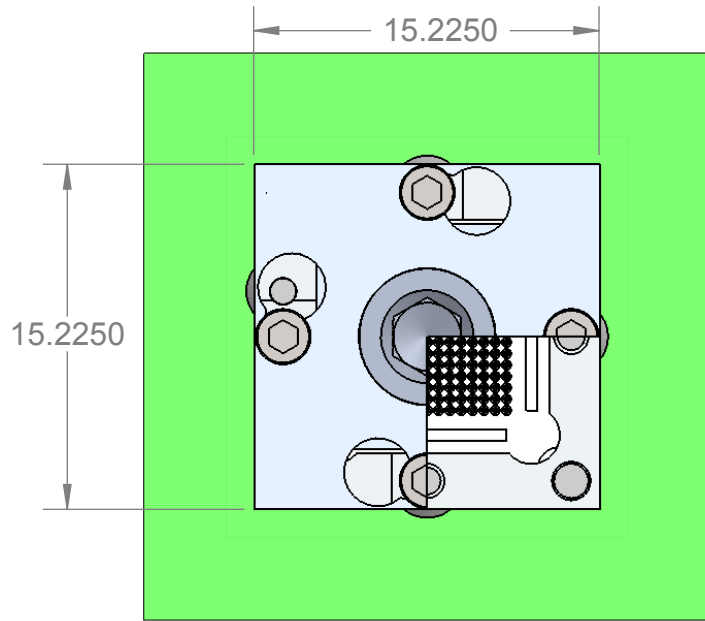

Description: Socket Assembly SBT-BGA 8x8mm, 0.5mm pitch, 14x14 array

Primary dimension units are millimeters, Secondary dimension units are [inches].

Tolerances: diameters $\pm 0.03\text{mm}$ [$\pm 0.001^\circ$], PCB perimeters $\pm 0.13\text{mm}$ [$\pm 0.005^\circ$], PCB thicknesses $\pm 0.18\text{mm}$ [$\pm 0.007^\circ$], pitches (from true position) $\pm 0.08\text{mm}$ [$\pm 0.003^\circ$], all other tolerances $\pm 0.13\text{mm}$ [$\pm 0.005^\circ$] unless stated otherwise. Materials and specifications are subject to change without notice.

Insulation Plate Specification

SBT-BGA-7003 Drawing

Ironwood Electronics, Inc.
 Tele: (800) 404-0204
 www.ironwoodelectronics.com

WEIGHT: 12.43
 MATERIAL:
 FINISH:

STATUS: Released

DRAWN BY: Vinayak R

File: SBT-BGA-7003

SHEET 4 OF 4

SCALE: 2:1

DATE: 5/21/2009

REV. A