

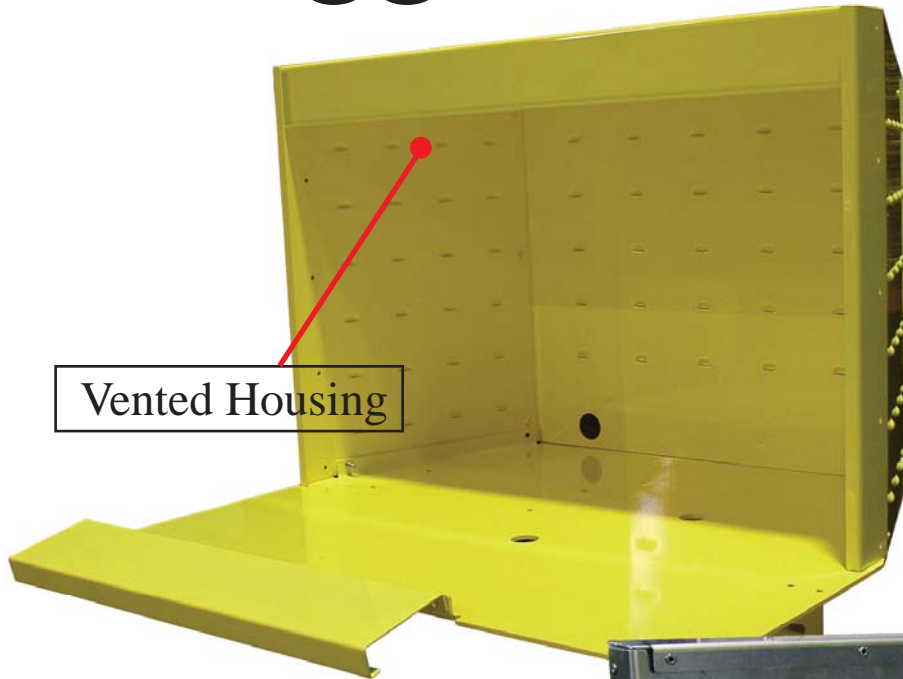

Thin Client Kiosk

Rugged Data Center

Shown in standard "safety yellow" color



Vented Housing

Protection
for your
plant's PCs

Shown with optional stainless steel
construction

Clear Lexan Panel



Available in
custom applications

Shown with 16" diagonal monitor



Top view

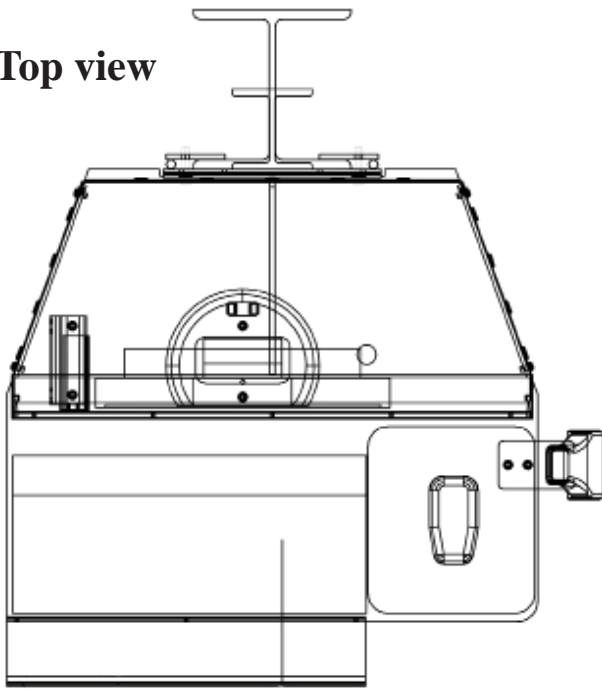

Side view

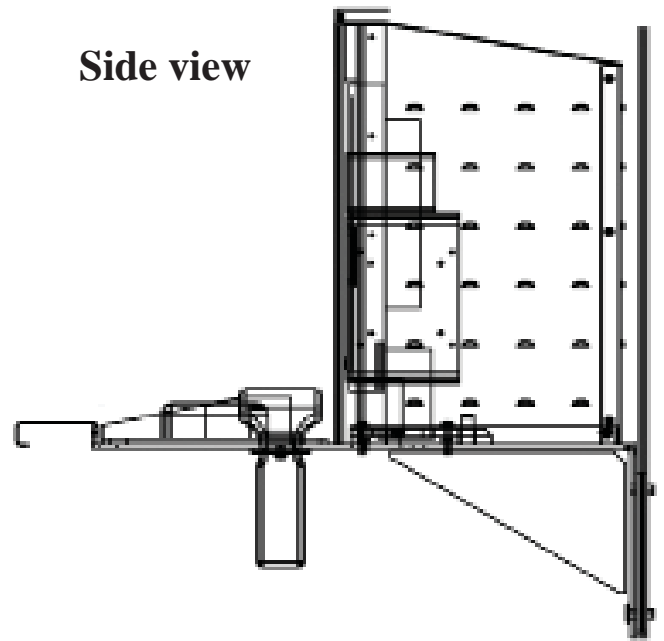

Features:

- Durable all-steel construction
- Vented cabinet
- Sliding front Lexan panel for equipment access
- Safety yellow steel or all stainless construction
- Welded and riveted construction
- Fits all keyboard/mouse configurations
- Built in ergonomic wrist rest
- Accommodates most flat screen monitors
- Suitable for all weather environments
- Standard wall, pole or column mount
- Interior space for manuals, forms or other items
- Fully assembled and easy to install
- Protects equipment from impact damage
- Isolates equipment from dirt, dust and water damage
- Prolongs the life of an investment
- Can be designed for use with articulating arm
- Fan cooled, non-vented design available
- Optional pedestal mount available
- One-year warranty

Specifications:

- 16 ga. stainless or powder-coated steel enclosure
- 7 ga. stainless or powder-coated steel base
- 1/4" stainless or powder-coated column mount brackets (standard)
- Dust sealed, 1/4" clear Lexan front panel
- Heavy "T" beam pedestal in stainless or powder coated steel (optional)
- Standard mount accommodates up to an 8" "T" beam column to minimum 3" pole
- Four-bolt pattern mounts to any suitable flat surface
- Overall dimensions:
18" H 26.5" W 26.5" D
- Weight approx. 65 lbs.

Have a question about Metal Control
or Material Handling Products?

**Ask the
Magnet Man**



Made in USA

Please visit our website:

www.MPIMAGNET.com

For more products and information