

STI BOPPER STOPPER®

Smaller-size Covers to Protect Everything From Electrical Outlets to Push Buttons

Inexpensive and highly durable, these hinged covers live up to their name and can be used in a wide range of applications. Bopper Stopper can take hard knocks in stride while protecting digital keypads, electrical outlets, smaller-size pull stations, biometrics, volume or lighting controls and push buttons to name just a few. The covers and hinges are molded of super tough polycarbonate material. The devices feature a stainless steel torsion spring to keep the cover closed (excludes STI-6520). Bopper Stoppers come complete with installation screws and gasket.

Carries a Lifetime Guarantee

As all STI protective covers, these Bopper Stoppers are backed by a lifetime guarantee against breakage and damage in normal use. They are also highly cost effective and easy to install.



STI-6518



STI-6520



STI-6522



STI-6528

Features

- Molded from super tough polycarbonate material.
- Stainless steel torsion spring maintains the cover in a closed position (excludes STI-6528).
- Protects against both vandalism and accidental damage.
- Their many uses include protecting push button units, smaller-sized pull stations, keypads, electrical outlets, volume or lighting controls and shutdown switches.
- Covers are backed by a lifetime guarantee against breakage in normal use.
- Covers come complete with mounting hardware and gasket.
- Gasket replacement recommended after five years.
- Polycarbonate rated -40° to 120°F (-40° to 49°C).
- Helps stop ice and snow from making keypad units difficult to operate.
- Fast, easy installation.



Safety Technology International, Inc.

2306 Airport Road • Waterford, Michigan 48327-1209

Phone: 248-673-9898 • Fax: 248-673-1246 • Toll Free: 800-888-4784 • E-mail: info@sti-usa.com • Web: www.sti-usa.com

Europe Branch Office • Unit 49G Pipers Road • Park Farm Industrial Estate • Redditch • Worcestershire • B98 0HU • England

Tel: 44 (0) 1527 520 999 • Fax: 44 (0) 1527 501 999 • Freephone: 0800 085 1678 (UK only) • E-mail: info@sti-europe.com • Web: www.sti-europe.com

STI BOPPER STOPPER®

Dimensions and Technical Information

Model Available

- STI-6518** Bopper Stopper with spring loaded hinge - clear
- STI-6520** Bio Protector - identification reader cover, enclosed - smoke color
- STI-6521** Bopper Stopper for keyless lock, open - smoke color
- STI-6522** Bopper Stopper
- STI-6528** Bopper Stopper - weather cover for stand alone access control

Approvals

- Bopper Stopper (STI-6518 only) has been tested and approved or listed by:
- UL/cUL No. S2466 (Over fire alarm stations only)
 - UL/cUL No. S7255 (Over misc. signaling devices)
 - ADA Compliant
 - CSFM Approved for use over STI fire push button - indoors only

STI-6518

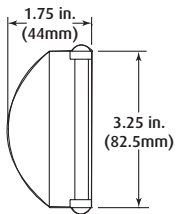
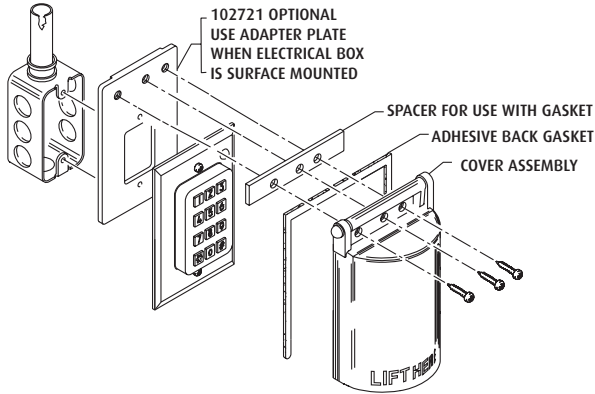

TOP VIEW

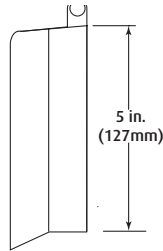

SIDE VIEW

STI-6528

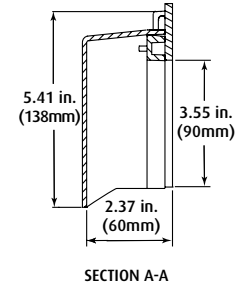
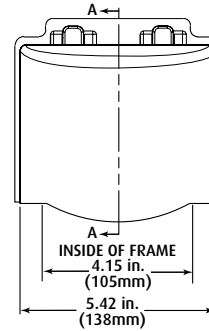
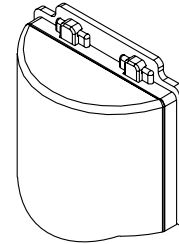

STI-6520

STI-6521

STI-6522

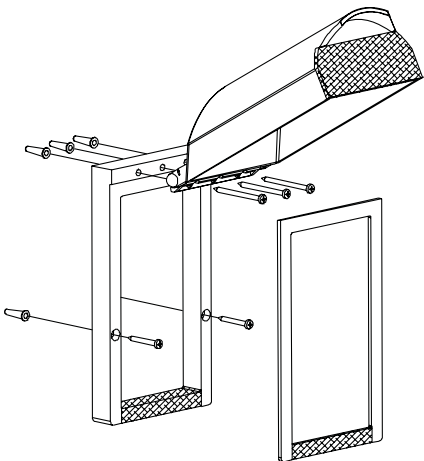

HATCHED SECTION REMOVED AT FACTORY FOR STI-6521

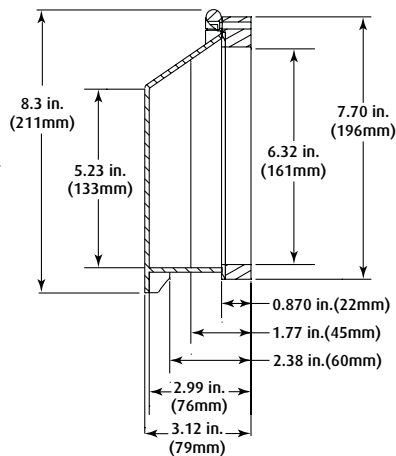

SIDE VIEW
STI-6520
STI-6521

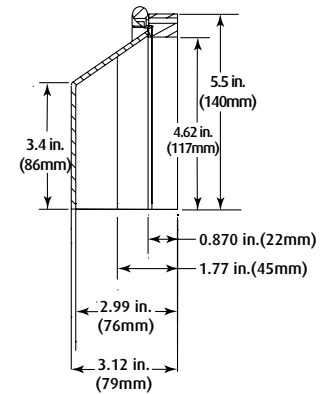

SIDE VIEW
STI-6522

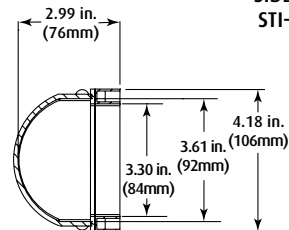

TOP VIEW