

COSASCO® BIO-PROBES

COSASCO® BIO-PROBES FOR MONITORING MICROBIOLOGICALLY INFLUENCED CORROSION (MIC)

Rohrback Cosasco Systems offers both retractable and retrievable bio-probes for monitoring microbiologically influenced corrosion (MIC). Cosasco® bio-probes offer plant operators a simple and effective tool for collecting samples for subsequent microbiological analyses in systems susceptible to MIC. Microorganisms, including bacteria, algae, and fungi can accelerate the corrosion process by as much as 10-1000 times. MIC is associated with localized attack, including pitting corrosion, crevice corrosion, stress corrosion cracking, and differential aeration cells.

If MIC goes undetected, it may erroneously result in increased inhibitor use in an attempt to reduce the corrosion. MIC must first be controlled by correct biocide treatment and the metal surfaces kept clean so that corrosion inhibitors protect the metal surfaces from general corrosion. MIC occurs in virtually every aqueous environment such as water treatment and sewage handling and treatment plants, but can also occur in oil & gas systems, chemical processing plants, and underground pipelines. The most common and damaging type of bacteria found in oil and gas applications are Sulfate Reducing Bacteria (SRB). SRBs chemically reduce sulfates to sulfides, producing sulfide ions that accelerate corrosion and may promote hydrogen embrittlement. Plant operators use biocides to kill the corrosion causing bacteria and other microorganisms. In addition physical cleaning through system flushing or mechanical cleaning with pigs are used to keep a system clean. Verification and adjustment of the treatment for effectiveness is required.

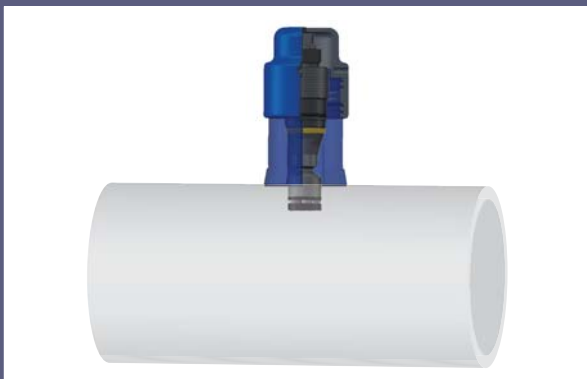

Retrievable Bio-probe positioned top of the line



Cosasco Model 6205 and 6215 Bio-probes

Cosasco Model 6205 and 6215 bio-probes provide an economical and safe means of collecting samples of sessile bacteria deposited on the metal surface in the process. The bio-probes have five sample elements, each with an exposed frontal area of 1cm². Each time a sample is required for analysis a successive element is removed and replaced with a new one, leaving the other four in place. With this successive change of elements, a longer exposure is obtained for each element, but still permits a relatively frequent sample to be taken for analysis.

Cosasco bio-probes offer:

- A balance to be made between biocides and corrosion inhibitors
- Simple and economical means of collecting bacteria samples
- Indicator for effective use of biocide treatments, reducing costs and minimizing dangerous effects to environment
- Flush Probe design ideal for frequently pigged pipelines
- Use in high or low pressure system, without the need for system shutdown
- Use with existing Cosasco Retrievable and Retractable equipment and accessories

Early detection is the key to controlling MIC once it has infected the system. Once the microorganisms have formed a bio-film, they become more resistant to biocides and can rapidly grow if not detected and controlled.



ROHRBACK COSASCO SYSTEMS

Corrosion Management Solutions

E-mail: sales@cosasco.com • Website: www.cosasco.com