

# FARR CART™

Mobile Unit for Workshop Welding



The Farr Cart™ is a mobile and powerful filter unit for welding in light engineering and repair workshops. With economic benefits built into this durable and user friendly design, it also allows and maintains a safe work environment.

## Standard Features & Benefits –

### SAFE WORK ENVIRONMENT

- High filtration efficiency
- High capture efficiency
- Efficient spotlight
- Low noise level

### ECONOMIC BENEFITS

- No installation time/cost
- Long filter lifetime
- Low power consumption
- Minimum of service requirements
- Low environmental impact

### USER-FRIENDLY DESIGN

- Ready to use
- High mobility even in narrow spaces
- Easy and safe operation
- Easy and quick maintenance
- Professional design to fit your workshop



### Technical Information

**Part no.**  
012624345

**Voltage**  
120V/60Hz/1ph

**kW**  
0.75 (1hp)

**Arm length**  
3m (10 ft.)

- Removable filter cover makes maintenance quick and easy



**FARR**  
*Air Pollution Control*



**Product Sheet**

**Farr Cart™**

SAFE AIR FOR A SAFE WORK ENVIRONMENT

# Clean Fresh Workshop Air

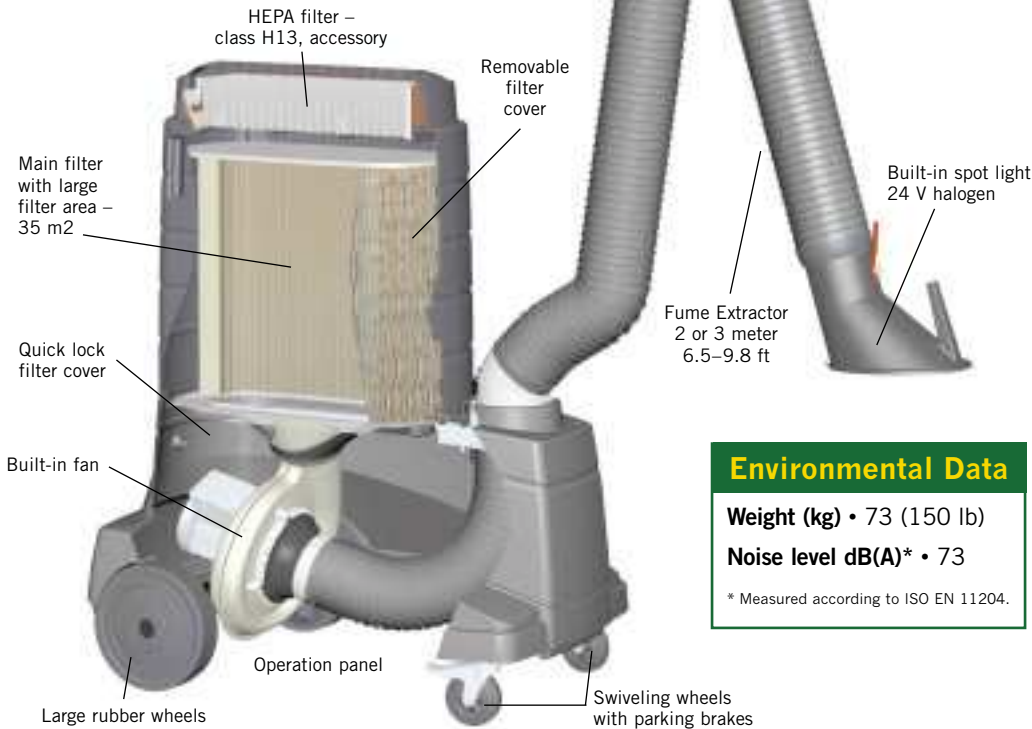

## Environmental Data

**Weight (kg) • 73 (150 lb)**

**Noise level dB(A)\* • 73**

\* Measured according to ISO EN 11204.

## Dust-free Filter Replacement



- Slacken and lift up the filter cover.
- Use the plastic bag from the new filter cartridge to pull and seal over the used filter.
- The unit is now ready for disposal.
- Fit the new filter cartridge and the filter cover.

## REPLACEMENT FILTER

**Part no. 012374023**

35 m<sup>2</sup> flame retardant pleated cellulose material. > 99% efficiency for welding fume. Measured according to the test procedures in EN 15012-1.

## Dimensions

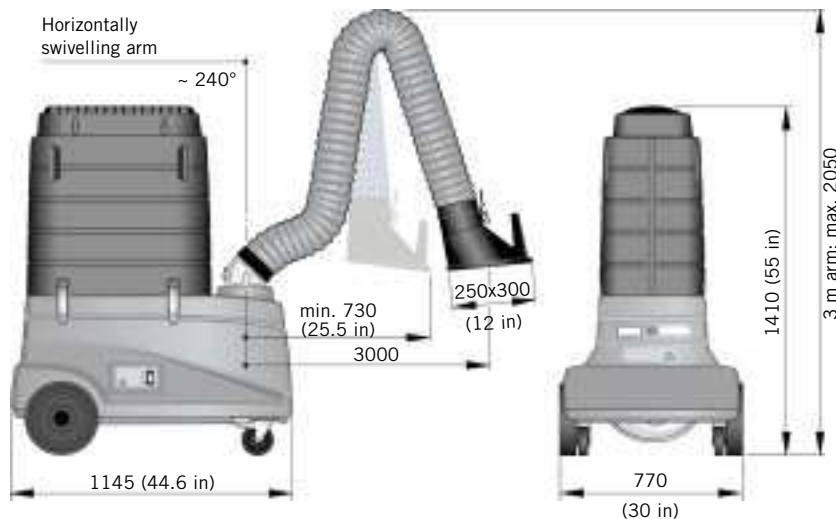

## Accessories

**HEPA FILTER H13**

**Part no. 012374016**

7.5m<sup>2</sup> high efficiency final filter, class H13.

**SPARK PROTECTION**

**Part no. 010372650**

For mounting in the hood to reduce risk of fire.

## RISK OF PERSONAL INJURY, FIRE OR EXPLOSION



The Farr Cart™ must not be used in an environment with danger of explosion or for dust or gases in explosive concentrations.



The Farr Cart™ must not be used for extracting toxic substances.



**FARR**

**Air Pollution Control**

SAFE AIR FOR A SAFE WORK ENVIRONMENT

Farr APC is a proud member of the Camfil Farr group.

3505 Airport Rd. • Jonesboro, AR 72401 • 870-933-8048 • Fax: 870-933-8380  
www.farrapc.com • e-mail: filterman@farrapc.com • 800-479-6801

© 2005 Farr Air Pollution Control  
Additional APC offices and factories in Laval, Canada (450-629-3030), and UK (44-121-707-8211)

