

## TRITON-270

The TRITON-270 is a complete computer, implemented on a board smaller than a credit card, and ready to be designed into your embedded system. TRITON-270 includes a PXA270 Intel® XScale™ processor, SDRAM and Flash memory. The integrated LCD-controller enables direct connection of a LCD screen, and the standard PCMCIA interface permits simple extension and integration into a target system.

The TRITON-270 is specifically targeted at embedded applications where size, high cpu-performance and low power consumption are critical factors.

Board highlights:

- 1,8V ultra low power memories on-board
- 3,3V 32-bit buffered external memory interface
- high efficiency programmable power supply
- Width reduced to 31mm, overall height reduced to 4,2mm (compared to other TRITON modules)
- All PXA270 interfaces available on a standard DIMM200 socket

## PXA270

Designed from the ground up for wireless clients and incorporating the latest Intel advances in mobile technology, the Intel PXA270 processor redefines what a wireless handheld can do by incorporating innovative new features while borrowing and enhancing others from the world of the PC. The Intel PXA27x processors are the first Intel XScale® technology-based processors to include Intel® Wireless MMX™ technology to enable high-performance multimedia acceleration with an industry proven instruction set. Another innovative feature is the Intel® Quick Capture technology which provides one of the industry's most flexible and powerful camera interfaces for capturing digital images and video. And while performance abounds in the Intel PXA27x processor, power consumption is also a critical component. The new capabilities of Wireless Intel SpeedStep® Technology provide a quantum leap forward in low-power operation.

## Redboot™

TRITON™ is delivered with pre-installed Redboot™ firmware. Redboot™ supports several low-level-debugging options and file download via serial XModem. These files can additionally be stored into the permanent flash-memory to be started by command or power-on.

## Board Features (Standard)

- Intel XScale™ PXA270 (312/416/520MHz)
- 32/64 MByte mobile SDRAM (1,8V ultra low power, 16/32bit)
- 8/16 Mbyte wireless Flash memory (1,8V ultra low power, 16bit)
- Buffered 32bit 3,3V external memory interface
- Single 3,3V power supply.
- Redboot™ firmware
- Extremely small DIMM200-module (67,6mm x 31 mm x 4,2mm)
- Glueless connectable to a SMSC LAN91C111 10/100Mbit/s Ethernet controller
- 3,3V memory interface may completely powered off.
- PMIC (power management integrated circuit) onboard.

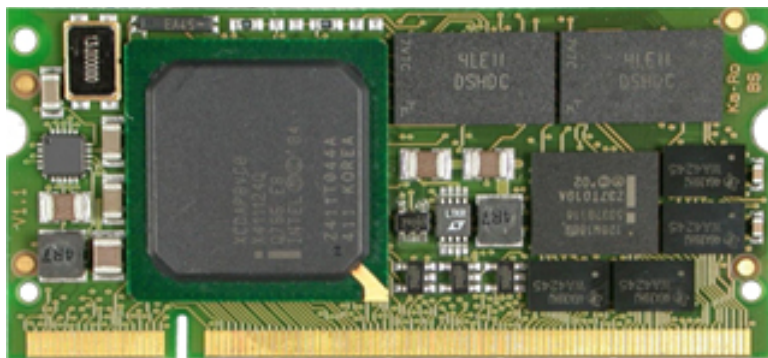
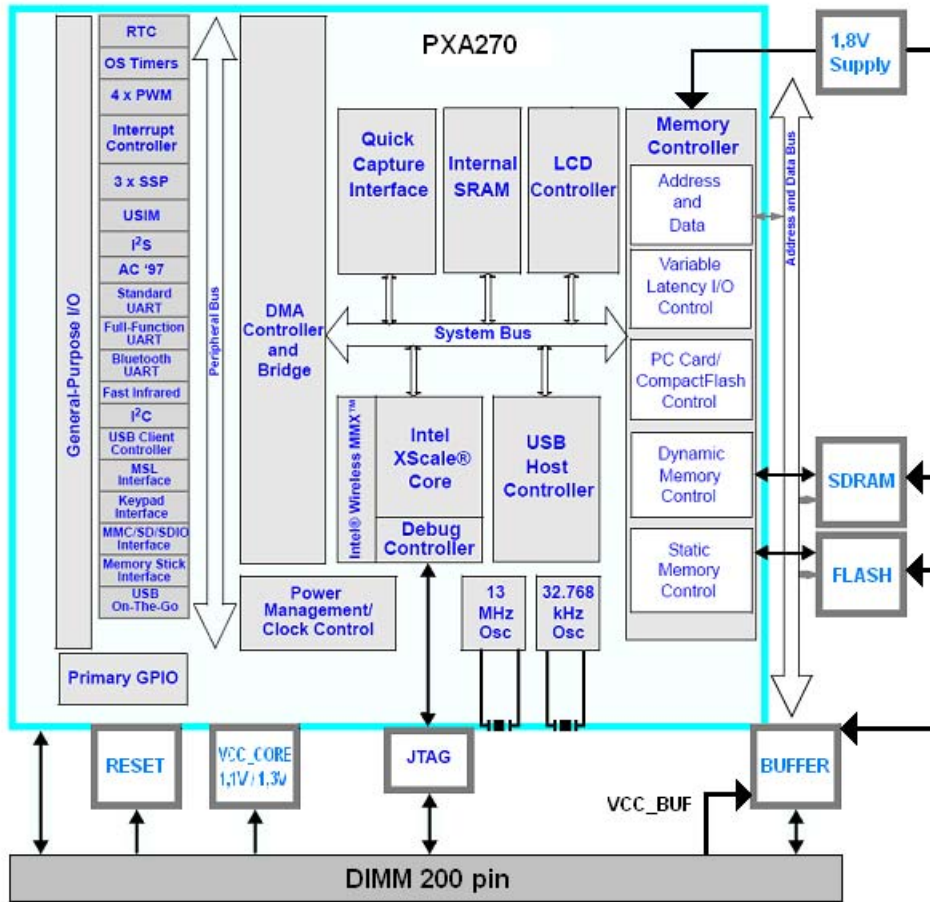

Ordering information

Order Number	PXA270	SDRAM	Flash
TRITON-270/520/64S/16F	520MHz	64MB	16MB

### DIMM200 connector pinout (part 1/3)

Pin	Signal	Primary Function /Comment	Secondary Function	Third Function	Supply
1	GPIO0				3V3
2	GPIO1				3V3
3	GPIO9	HZ_CLK		FFCTS / CHOUT0	3V3
4	GPIO10	FFDCD / HZ_CLK		USB_P3_5 / CHOUT1	3V3
5	SYS_EN				3V3
6	BATT_FAULT#	Note: Output, leave unconnected			3V3
7	VDD_FAULT#	Note: OC, 22k pull-up on-board			3V3
8	TRST#	Note: 22k to RESET# on-board			3V3
9	TDI				3V3
10	TDO				3V3
11	TMS				3V3
12	TCK	Note: 22k pull-down on-board			3V3
13	3V3				-
14	GND				-
15	GPIO74		L_FCLK_RD		VCC_LCD
16	GPIO77		L_BIAS		VCC_LCD
17	GPIO87	PCE2# / SSPTXD2	LDD17	USB_P3_1 / SSPSFRM2	VCC_LCD
18	GPIO76		L_PCLK_WR		VCC_LCD
19	GPIO73		LDD15		VCC_LCD
20	GPIO14	L_VSYNC	SSPSFRM2	UCLK	VCC_LCD
21	GPIO72		LDD14		VCC_LCD
22	GPIO70		LDD12		VCC_LCD
23	GPIO75		L_LCLK_A0		VCC_LCD
24	GPIO69		LDD11		VCC_LCD
25	GPIO64		LDD6		VCC_LCD
26	GPIO62		LDD4		VCC_LCD
27	GPIO61		LDD3		VCC_LCD
28	VCC_LCD				-
29	GPIO68		LDD10		VCC_LCD
30	GPIO60		LDD2		VCC_LCD
31	GPIO86	SSPRXD2 / PCE1#	LDD16	USB_P3_5	VCC_LCD
32	GPIO58		LDD0		VCC_LCD
33	GPIO59		LDD1		VCC_LCD
34	GPIO63		LDD5		VCC_LCD
35	GPIO66		LDD8		VCC_LCD
36	GPIO65		LDD7		VCC_LCD
37	GPIO67		LDD9		VCC_LCD
38	GPIO71		LDD13		VCC_LCD
39	GPIO19	SSPSCLK2	L_CS	UCLK	VCC_LCD
40	GND				-
41	VCC_USB				-
42	GND				-
43	GPIO44	BTCTS		CIF_LV	3V3
44	GPIO43	ICP_TXD	BTTXD	CIF_FV	3V3
45	GPIO41	FFRXD / KP_MKOUT7	USB_P2_7 / FFRTS	SSPRXD3	3V3
46	GPIO88	USBHPWR1	SSPRXD2	SSPSFRM2	3V3
47	GPIO92	MMDAT0	MSBS		3V3
48	GPIO118	SDA			3V3
49	GPIO111	MMDAT3 / MMCCS1			3V3
50	GPIO34	FFRXD / USB_P2_2	KP_MKIN3	SSPSCLK3	3V3
51	GPIO23	CIF_MCLK	SSPSCLK		3V3
52	GPIO89	SSPRXD3 / AC97_SYSCLK	USBHPEN1	FFRI / SSPTXD2	3V3
53	GPIO25	CIF_LV	SSPRXD		3V3
54	GPIO117	SCL			3V3
55	GPIO26	SSPRXD	CIF_PCLK	FFCTS	3V3
56	GPIO39	KP_MKIN4 / USB_P2_6	FFTXD	SSPSFRM3	3V3
57	GPIO24	CIF_FV	SSPSFRM		3V3
58	GPIO112	MMCMD	MSINS#		3V3
59	GPIO38	FFRI / SSPTXD3	KP_MKIN4 / SSPTXD2	USB_P2_3 / PWM_OUT1	3V3
60	GPIO45	AC97_SYSCLK	BTRTS	CIF_PCLK / SSPSYSCLK3	3V3
61	GPIO36	FFDCD / USB_P2_4	SSPSCLK2	KP_MKIN7	3V3
62	GPIO32	MSSCLK	MMCLK		3V3
63	GPIO22	SSPEXTCLK2 / KP_MKOUT7	SSPSCLKEN2 / SSPSYSCLK2	SSPSCLK2	3V3
64	GPIO110	MMDAT2 / MMCCS0			3V3
65	GPIO27	SSPEXTCLK / SSPSYSCLK	SSPSCLKEN	CIF_DD0 / FFRTS	3V3
66	GPIO16	KP_MKIN5	PWM_OUT0	FFTXD	3V3

Refer to PXA270 datasheet for signal description - non-standard signals marked blue

### DIMM200 connector pinout (part 2/3)

Pin	Signal	Primary Function /Comment	Secondary Function	Third Function	Supply
67	GPIO29	AC97_SDATAIN0 / SSPRXD2	I2S_SDATAIN	SSPSCLK	3V3
68	GPIO17	KP_MKIN6	CIF_DD6 / PWM_OUT1		3V3
69	GPIO30	I2S_SDATA_OUT	AC97_SDATA_OUT	USB_P3_2	3V3
70	GPIO109	MMDAT1	MMSDIO		3V3
71	GPIO113	I2S_SYCLK	AC97_RESET#	USB_P3_3	3V3
72	USBC_P				VCC_USB
73	GPIO40	SSPRXD2 / KP_MKOUT6	FFDTR	USB_P2_5 / SSPSCLK3	3V3
74	USBC_N				VCC_UCB
75	GPIO46	ICP_RXD	STD_RXD / PWM_OUT2		3V3
76	GND				-
77	GPIO31	I2S_SYNC	AC97_SYNC	USB_P3_6	3V3
78	3V3				-
79	GPIO11	EXT_SYNC0 / CHOUT0	SSPRXD2 / PWM_OUT2	USB_P3_1 / 48_MHZ	3V3
80	GPIO42	BTRXD	ICP_RXD	CIF_MCLK	3V3
81	GPIO37	FFDSR / USB_P2_8	SSPSFRM2	KP_MKIN3 / FFTXD	3V3
82	RESET_OUT#				3V3
83	GPIO12	EXT_SYNC1 / CHOUT1	CIF_DD7 / PWM_OUT3	48_MHZ	3V3
84	USBH_P1				VCC_USB
85	GPIO28	AC97_BITCLK / I2S_BITCLK	I2S_BITCLK	SSPSFRM	3V3
86	USBH_N1				VCC_USB
87	GPIO13	CLK_EXT / SSPTXD2	KP_MKIN7	MK_MKIN7	3V3
88	GPIO115	DREQ0 / UEN	CIF_DDS3 / UVS1#	MBREQ / PWM_OUT1	3V3
89	GPIO35	FFCTS	USB_P2_1 / KP_MLOUT6	SSPSFRM3 / SSPTXD3	3V3
90	VCC_USIM				-
91	UIO				VCC_USIM
92	GPIO116	CIF_DD2 / DVAL0	AC97_SDATAIN0 / UVS2#	UDET / MBGNT	3V3
93	GPIO114	CIF_DD4	UVS0		3V3
94	GPIO47	CIF_DD0 / ICP_TXD	ICP_TXD	PWM_OUT3	3V3
95	GPIO91	KP_MKIN6	USB_P3_1 / UCLK	CIF_DD5	VCC_USIM
96	GND				-
97	GPIO90	KP_MKIN5	USB_P3_5 / URST#	CIF_DD4	VCC_USIM
98	VCC_BB				-
99	xRDYB	Note: RDY = xRDYA & yRDYB	22k pull-up on-board		3V3
100	GPIO99	KP_DKIN6	AC97_SDATAIN1	KP_MKIN5 / FFTXD	3V3
101	xRDYA	Note: RDY = xRDYA & yRDYB	22k pull-up on-board		3V3
102	GPIO95	KP_DKIN2 / AC97_RESET#	CIF_DD4	KP_MKIN6	3V3
103	GPIO50	CIF_DD5 / BB_OB_DAT1	PIOIR#	SSPSCLK2	VCC_BB
104	GPIO53	FFRXD / BB_OB_STB	USB_P2_3 / CIF_MCLK	SSPSYSCLK	VCC_BB
105	GPIO102	KP_MKIN2 / PCE1#		FFRXD	3V3
106	GPIO94	KP_DKIN1 / AC97_SYNC	CIF_DD5		3V3
107	VCC_BATT				-
108	GPIO101	KP_MKIN1			3V3
109	GPIO106	CIF_DD9	KP_MKOUT2		3V3
110	RESET_IN#	Note: Manual Reset Input.	Connect to GND for manual reset	Otherwise leave open	3V3
111	GPIO51	CIF_DD2 / BB_OB_DAT3	PIOIW#		VCC_BB
112	GPIO52	CIF_DD4 / BB_OB_CLK	SSPSCLK3		VCC_BB
113	GPIO48	CIF_DD5 / BB_OB_DAT1	POE#		VCC_BB
114	GPIO84	SSPSCLK3	BB_IB_STB	CIF_FV	VCC_BB
115	GPIO81	SSPTXD3	CIF_DD0 / BB_OB_DAT0		VCC_BB
116	GPIO55	CIF_DD1	BB_IB_DAT1	PREG#	VCC_BB
117	GPIO85	FFRXD / PCE1#	DREQ2 / BB_IB_WAIT	CIF_LV	VCC_BB
118	GPIO54		BB_OB_WAIT / PCE2#	CIF_PCLK	VCC_BB
119	GND				-
120	GPIO83	SSPFRM3	BB_IB_CLK / FFTXD	CIF_DD4 / FFRTS	VCC_BB
121	GPIO82	SSPRXD3	BB_IB_DAT0	CIF_DD5 / FFDTR	VCC_BB
122	GPIO105	CIF_DD1 / PCE2#	KP_MKOUT2		3V3
123	GPIO57	IOIS16#	BB_IB_DAT3	SSPTXD	VCC_BB
124	GPIO56	PWAIT# / USB_P3_4	BB_IB_DAT2		VCC_BB
125	GPIO108	CIF_DD7 / CHOUT0	KP_MKOUT5		3V3
126	GPIO104	CIF_DD2 / PSKTSEL	KP_MKOUT1		3V3
127	GPIO97	KP_DKIN4	DREQ1 / MBGNT	KP_MKIN3	3V3
128	GPIO107	CIF_DD8	KP_MKOUT4		3V3
129	GPIO96	KP_DKIN3	MBREQ / DVAL1	FFRXD / KP_MKOUT6	3V3
130	GPIO100	KP_MKIN0	DREQ2	FFCTS	3V3
131	GPIO93	KP_DKIN0 / AC97_SDATAOUT			3V3
132	VCC_MEM_OUT (1V8)	Note: leave unconnected			-
133	GPIO98	KP_DKIN5 / AC97_SYCLK	CIF_DD0	KP_MKIN4 / FFRTS	3V3

Refer to PXA270 datasheet for signal description - non-standard signals marked blue

### DIMM200 connector pinout (part 3/3)

Pin	Signal	Primary Function /Comment	Secondary Function	Third Function	Supply
134	GPIO103	CIF_DD3	KP_MKOUT0		3V3
135	GND				-
136	xBUFEN#	Note: 22k pull-up on-board	L: Enable xMD0..32 buffers		VCC_BUF
137	xMA9				VCC_BUF
138	xMA10				VCC_BUF
139	xMA7				VCC_BUF
140	xMA8				VCC_BUF
141	xMA5				VCC_BUF
142	xMA6				VCC_BUF
143	xMA3				VCC_BUF
144	xMA4				VCC_BUF
145	xMA2				VCC_BUF
146	xMA1				VCC_BUF
147	xMA0				VCC_BUF
148	GPIO33 (output only)		PWE#		VCC_BUF
149	GPIO79 (output only)	PSKTSSEL#	CS3#	PWM_OUT2	VCC_BUF
150	xRD/WR#				VCC_BUF
151	GPIO78 (output only)	PCE2#	CS2#		VCC_BUF
152	GPIO15 (output only)	PCE1#	CS1#		VCC_BUF
153	xOE#				VCC_BUF
154	xWE#				VCC_BUF
155	GPIO80 (output only)		CS4#	PWM_OUT3	VCC_BUF
156	GPIO33 (output only)	xDVAL1	CS5#	MBGNT	VCC_BUF
157	GPIO21 (output only)		xDVAL0	MBGNT	VCC_BUF
158	xSDCAS#				VCC_BUF
159	xSDCLK0				VCC_BUF
160	xDQM3				VCC_BUF
161	xDQM2				VCC_BUF
162	GND				-
163	VCC_BUF				-
164	xMD30				VCC_BUF
165	xMD31				VCC_BUF
166	xMD28				VCC_BUF
167	xMD29				VCC_BUF
168	xMD26				VCC_BUF
169	xMD27				VCC_BUF
170	xMD24				VCC_BUF
171	xMD25				VCC_BUF
172	xMD22				VCC_BUF
173	xMD23				VCC_BUF
174	xMD20				VCC_BUF
175	xMD21				VCC_BUF
176	xMD18				VCC_BUF
177	xMD19				VCC_BUF
178	xMD16				VCC_BUF
179	xMD17				VCC_BUF
180	xDQM0				VCC_BUF
181	xDQM1				VCC_BUF
182	VCC_BUF				-
183	GND				-
184	xMD15				VCC_BUF
185	xMD14				VCC_BUF
186	xMD13				VCC_BUF
187	xMD12				VCC_BUF
188	xMD11				VCC_BUF
189	xMD10				VCC_BUF
190	xMD9				VCC_BUF
191	xMD8				VCC_BUF
192	xMD7				VCC_BUF
193	xMD6				VCC_BUF
194	xMD5				VCC_BUF
195	xMD4				VCC_BUF
196	xMD3				VCC_BUF
197	xMD2				VCC_BUF
198	xMD1				VCC_BUF
199	xMD0				VCC_BUF
200	GND				-

Refer to PXA270 datasheet for signal description - non-standard signals marked blue